



GERSTENBERG POLARON PIN ROTOR MACHINE AND PLASTICATOR

DESIGNED FOR PERFORMANCE AND FLEXIBILITY

The Polaron pin rotor machine is designed to handle a wide range of products in the oils and fats processing industry, including:

- Table margarine
- Puff pastry margarine
- Industrial margarine
- Shortening
- CBS (Cocoa Butter Substitutes)
- AMF blends
- Low-fat and texturised butter products

By kneading and working the product at variable speeds, the Polaron pin rotor machine fine-tunes texture, plasticity, and viscosity, ensuring excellent workability and product performance.

FACTORY-FRIENDLY, HYGIENIC, AND EASY TO MAINTAIN

Designed with efficiency, hygiene, and flexibility in mind, the Polaron pin rotor machine is compact, cleanable, and easy to service. For production facilities where floor space is at a premium, the machine can be delivered in a stacked configuration with up to three pin rotor machines mounted on a single frame. This allows you to increase capacity and processing flexibility while minimising the amount of space required in your production line - without compromising performance.

In addition to its factory-friendly design, the Polaron pin rotor machine is built for easy cleaning, servicing, and maintenance. It is fully compatible with CIP (Clean-in-Place) systems for fast, hygienic cleaning, and all product-contacting parts are made in AISI 316 stainless steel to meet the strict hygiene standards of the food industry.

Semi-balanced, sanitary design seals ensure product safety while simplifying service access, helping you keep down-time to an absolute minimum.

ENHANCE PROCESSING WITH THE POLARON PLASTICATOR

In certain formulations - particularly those based on palm oil or other slow-crystallising fats - additional processing after primary crystallisation can significantly improve product plasticity, texture, and workability. The Polaron plasticator is an optional downstream unit designed to provide this extra kneading and working of the product.

OPTION:
Automatic drain valves

GERSTENBERG POLARON PIN ROTOR MACHINE AND PLASTICATOR

POLARON PIN ROTOR MACHINE 2X80 L. AND POLARON PLASTICATOR 25 L.

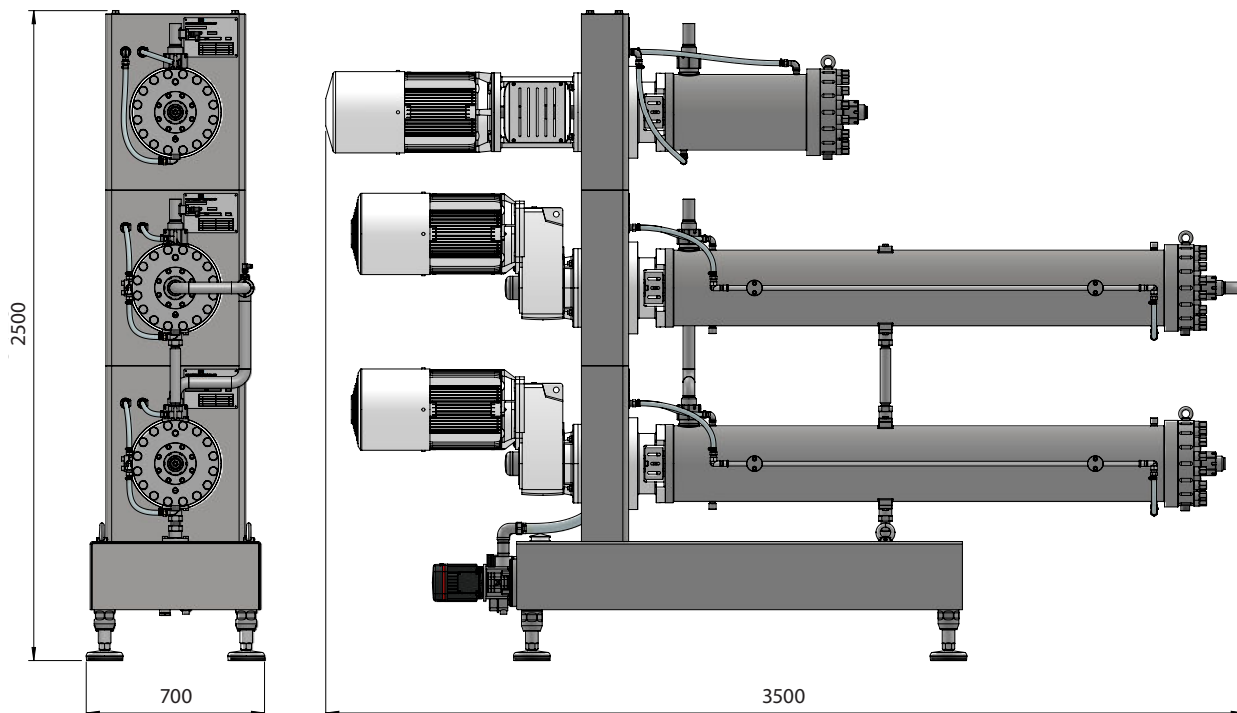

Gerstenberg Polaron pin rotor machine and plasticator		Plasticator type 25 l.	Pin rotor machine type 25 l.	Pin rotor machine type 50 l.	Pin rotor machine type 80 l.	Pin rotor machine type 100 l.	Pin rotor machine type 200 l.
Max. pressure	bar	120	120	120	120	120	75
Cylinder volume	l.	25	25	50	80	100	200
Pin rotor speed	rpm	300-900	50-300	50-300	50-300	50-300	50-220
Gear motor	kW	7.5	7.5	7.5	11	11	18.5
PT-100 temperature sensor	-	1 pc.	1 pc.	1 pc.	1 pc.	1 pc.	1 pc.
Water attemperation unit	kW	9	9	9	9	9	9
Water circulation pump	kW	0.37	0.37	0.37	0.37	0.37	0.37
Product piping connections	mm	DN40	DN40	DN40	DN40	DN40	DN40 & DN50