

GERSTENBERG POLARON PUMP

BUILT FOR PERFORMANCE AND HYGIENIC PROCESSING

The Polaron high pressure pump is carefully engineered to deliver stable, gentle product flow, protecting product integrity while ensuring efficient, reliable operation throughout your process line.

Its self-lubricating design reduces wear on moving parts, minimises maintenance requirements, and extends equipment lifespan. The pump is also fully compatible with CIP (Clean-in-Place), simplifying hygiene management and reducing downtime.

Meeting the latest market demands for food safety and sanitary processing, the Polaron pump complies with 3-A Sanitary Standards, with all product-contact surfaces constructed from AISI 316 stainless steel or higher grades for maximum durability and corrosion resistance.

Standard plungers are made in duplex stainless steel with a special food-grade coating which offers very high wear-resistance.

For added flexibility, the Polaron high pressure pump features a variable capacity easily adjusted via a frequency converter, allowing you to optimise performance for different products and production volumes.

OPTIONS:

- Possibility of injection of N₂ for aerating of shortening and similar products
- Ball valves
- Flushed seals

EXAMPLES OF PRODUCTS

- Table margarine
- Puff pastry margarine
- Industrial margarine
- Shortening
- CBS (Cocoa Butter Substitute)
- Ghee
- AMF (Anhydrous Milk Fat)
- Low fat butter
- Texturised butter

GERSTENBERG POLARON PUMP

POLARON PUMP PP-XX/80

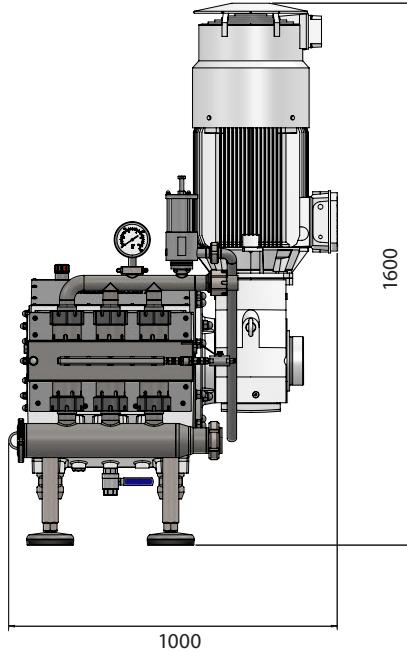

1000

POLARON PUMP PP-XX/100

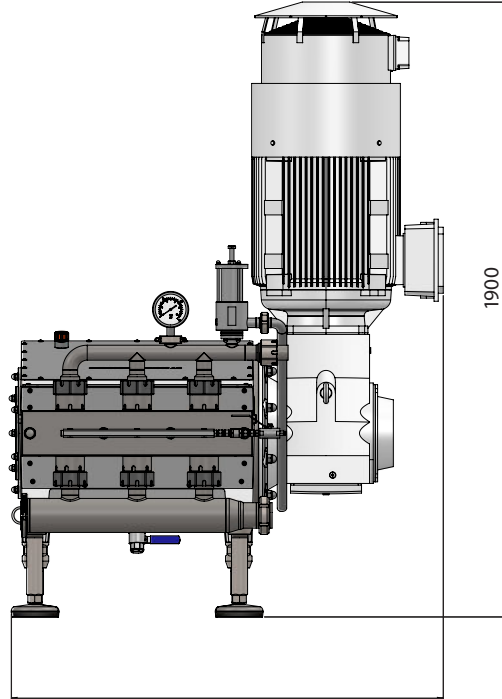

1300

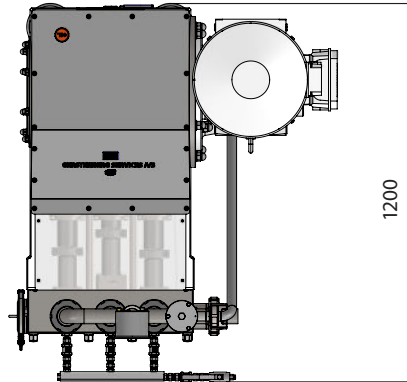

1200

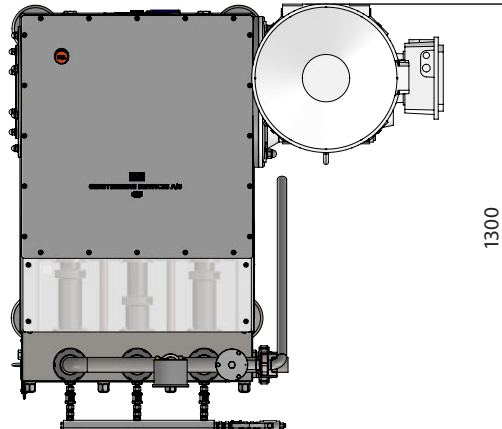

1300

Gerstenberg Polaron pump		PP-55/80		PP-60/80		PP-70/100		PP-94/100
Nominal capacity	l/h	3,070	4,710	3,660	5,650	6,010	9,220	14,190
Max. capacity	l/h	6,150	6,570	7,310	7,820	12,010	13,300	23,980
Max. working pressure	bar	120		120		120		60
Plunger diameter	mm	55		60		70		94
Stroke	mm	80		80		100		100
Nominal motor power	kW	22	22	22	30	30	45	45
Nominal speed at 50 Hz	rpm	94	144	94	144	90	139	118
Machine weight approx.	kg	1,100		1,150		1,650		1,700

The above capacities are nominal values and may vary depending on product composition and flow rate. Max. working pressure and max. capacity cannot necessarily be obtained at the same time.